

SYSPEND™ VL-MOTION ARM, TYPE 4



INDUSTRY STANDARDS

Maintains NEMA Type 4 and 12 and IEC IP66 enclosure rating when properly installed per Hoffman instructions.

APPLICATION

Vertical motion pendant arm effortlessly lifts, lowers and repositions HMI enclosures in NEMA Type 4 and 12 environments. Gas spring counterbalance can be adjusted for loads of 30-100 lb. Release handle and locking mechanism are ideal for applications where machine vibration is a concern.

FEATURES

- Field-adjustable gas-spring counterbalance supports loads of 30-100 lbs.
- Gas springs are set to maximum pressure (100 lb. load) and lifting force can be reduced through a sealed access cap in the top of the arm (*Lifting force cannot be increased once spring pressure is reduced.*)
- Provides 13 in. of vertical height adjustment

- Release handle (included with arm) automatically locks arm in place when repositioned vertically (release handle is required to operate the arm)
- Easily interfaces with Hoffman HMI enclosures using a 60-x-60-mm enclosure mounting pattern (enclosure must be ordered separately)
- 1.4-in. internal cable pathway maintains NEMA Type 4 and 12 enclosure rating and protects wires and cables
- Gasketed mounting surfaces at both ends of arm maintain seal integrity
- Enclosure and arm can be swiveled 320 degrees
- Wall-mount, machine-top-mount and post-top-mount options available
- Optional floorpost available

SPECIFICATIONS

- Aluminum construction
- RAL 7035 light-gray finish
- Gas spring counterbalance

BULLETIN: VM4

Standard Product

Catalog Number	AxBxC in./mm	Description*	Wall-Mount Adapter	Post-Top-Mount Adapter	Machine-Top-Mount Adapter	Load Capacity (lbs.)	Load Capacity (kg)	Arm Weight (lb.)	Arm Weight (kg)
VL22	6.72 x 25.50 x 3.50 171 x 648 x 89	VL-Motion Arm, 22-in.	VLWALL	VLPOST	VLMACHINE	30-100	14-45	20.0	9.07

*Mounting adapter required. Order separately.
Release handle included with arm.

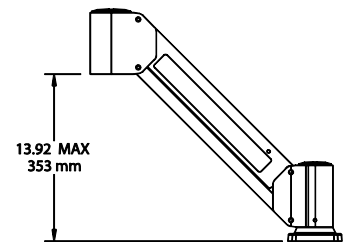
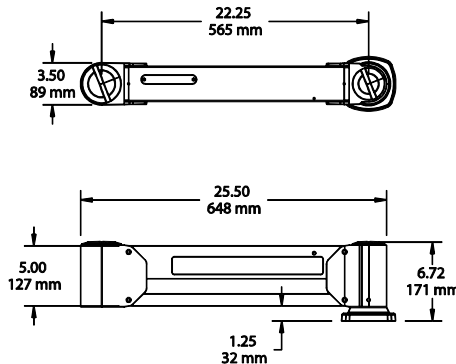
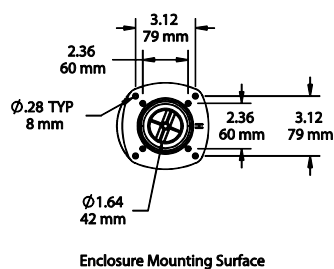

87948609

WALL-MOUNT ADAPTER



Order separately to install the SYSPEND™ VL-Motion Arm on a wall or vertical surface.

- RAL 7035 light-gray polyester powder paint finish
- Includes hardware to mount the adapter to the arm
- Hardware for mounting to the wall is not included

BULLETIN: VM4

Catalog Number	AxBxC in./mm	Description	Weight (lb.)	Weight (kg)
VLWALL	5.25 x 6.00 x 4.01 133 x 152 x 102	VL-Motion Arm Wall-Mount Adapter	8.0	3.63

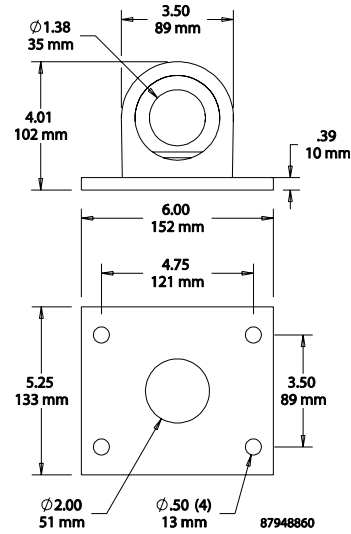

MACHINE-TOP-MOUNT ADAPTER



Order separately to install the SYSPEND™ VL-Motion Arm on a machine top or horizontal surface.

- RAL 7035 light-gray polyester powder paint finish
- Includes hardware to mount the adapter to the arm
- Hardware for mounting to a horizontal surface is not included

BULLETIN: VM4

Catalog Number	AxBxC in./mm	Description	Weight (lb.)	Weight (kg)
VLMACHINE	5.12 x 5.12 x 2.06 130 x 130 x 52	VL-Motion Arm Machine-Top-Mount Adapter	8.0	3.63

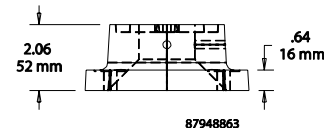
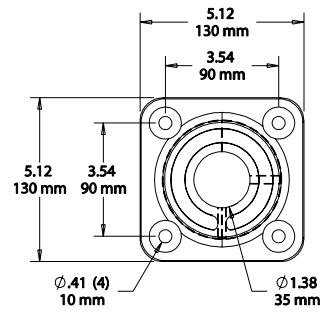

POST-MOUNT ADAPTER

Order separately to install the SYSPEND™ VL-Motion Arm on a 3.5-in. OD tube.

- RAL 7035 light-gray polyester powder paint finish
- Includes hardware to mount the adapter to the arm and set screws to attach to a tube

BULLETIN: VM4

Catalog Number	AxBxC in./mm	Description	Weight (lb.)	Weight (kg)
VLPOST	5.01 x 4.68 x 4.68 127 x 119 x 119	VL-Motion Arm Post-Mount Adapter	8.0	3.63

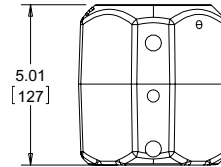
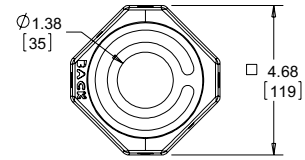

87948861

FLOORPOST WITH JUNCTION BOX

Provides method for mounting the SYSPEND™ VL and VHD Motion Arms when a structural surface is not available.

- Heavy-wall 3.5-in. structural tube welded to a 12 x 12 x 3/8-in.-thick baseplate
- Provides a "rough-in" point and pull box for power and network field wiring
- Includes internal CAT5 coupler and finger-safe power terminals
- Two conduit knock-outs can be opened to either 1/2 in. or 3/4 in.
- Fully gasketed 16 gauge cover panel on junction box can be used for additional conduit attachment
- Tough, molded ABS junction box is contoured to fit the post and is fluted into the post to protect cables

BULLETIN: VM4

Catalog Number	AxBxC in./mm	Description	Weight (lb.)	Weight (kg)
FLOORPOST	11.90 x 11.90 x 74.00 302 x 302 x 1880	Floorpost with Junction Box	65.0	29.48

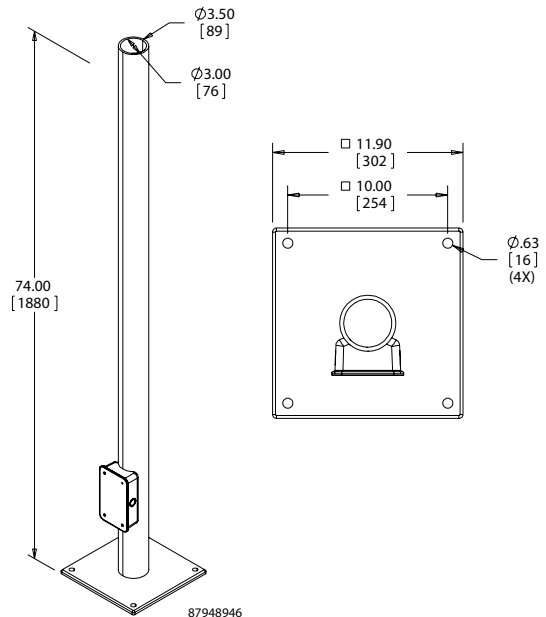

87948946

REPLACEMENT RELEASE HANDLE



Replacement release handle for use with the SYSPEND™ VL-Motion Arm. (Handle is included with the VL-Motion Arm.) Includes handle end supports with 491 mm (19.3 in.) tube that can be easily cut to length to fit the enclosure.

BULLETIN: HB1

Catalog Number	AxBxC in./mm	Description
VLHANDLE	3.88 x 1.38 x 19.30 99 x 35 x 490	Replacement Release Handle for VL-Motion Arm

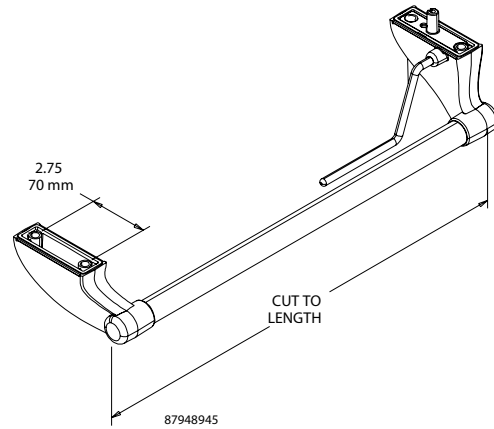

REPLACEMENT GAS SPRINGS

Includes instructions for field replacement of gas springs for the SYSPEND™ VL-Motion Arm.

BULLETIN: HB1

Catalog Number	AxB in./mm	Description
VLSPRINGS	2.00 x 15.00 51 x 381	Replacement Gas Springs for VL-Motion Arm

