

TYPE CWH 1000

COMMERCIAL FAN-FORCED WALL HEATERS

APPLICATIONS

Fast heat response, compact design and versatility make the CWH1000 Series heaters ideal for dens, basements, converted attics and breezeways, garages, bathrooms, small offices, workshops and similar areas. Also, adaptable to multiple installations in somewhat larger or odd shaped rooms.

FEATURES

Heating element is heavy duty steel fins brazed to steel sheathed tubular elements in a grid pattern that covers the entire discharge area.

FAN DELAY: On a call for heat, element is energized but fan is delayed until element is warm, eliminating the circulation of cold air during start up. When the thermostat is satisfied, the element is de-energized, but the fan continues until all heated air is discharged providing longer component life and higher comfort level.

Designed for easy installation. Heater is mounted prior to wiring. Both hands are free to make field connections in roomy compartment.

Motor is totally enclosed, impedance protected with permanently lubricated bearings.

Airflow system maximizes air volume at minimum noise level; 65 CFM.

Rugged louvered commercial grade steel grille creates downflow air pattern.

This heater is designed for installation in 2 x 4 or larger wall sections using the wall box provided. The heater may also be surface mounted to the wall by using the Surface Mounting Frame, Model No. CWHSM (order separately).

The heater may be wired with standard building wire (60°C). Refer to specification chart for correct supply voltage and wire size.

Built-in snap action thermostat (no radio/TV interference; 40° - 85°F).

A hole plug is provided for tamper resistant installations.

Includes Built-In Disconnect Switch.

Northern White powder paint finish.



SELECTION CHART

CATALOG NO.	VOLTS	AMPS	WATTS	BTU/HR	WIRE SIZE
CWH1101DS	120	8.4	1000	3413	14AWG
		4.2	500	1706	
CWH1151DS	120	12.5	1500	5120	12AWG
		6.25	750	2560	
CWH1201DS	120	15	1800	6143	12 AWG
CWH1202DS	240	8.4	2000	6826	14AWG
		4.2	1000	3413	
	208	7.3	1500	5120	
		3.61	750	2560	
CWH1207DS	277	7.3	2000	6826	14AWG
		3.61	1000	3413	
	240	6.25	1500	5120	
		3.2	750	2560	
CWH1157DS	277	5.5	1500	5120	14AWG
		2.75	750	2560	
	240	4.7	1125	3840	
		2.35	562	1920	
CWH1208DS	208	9.6	2000	6826	14AWG
		4.8	1000	3413	

MOUNTING LIMITATIONS

1. Do not install heater closer than 4" from floor.
2. Do not install heater behind towel rack, behind door, in floor, in ceiling, in closet, or where air flow may be obstructed.

ACCESSORIES

CAT. NO.	DESCRIPTION
CWHSM	Surface Mounting Frame (Accessory). Order separately. 12 ¹ / ₂ "H x 10 ³ / ₈ "W x 4"D.
CWHS1	1" Semi-Recess Mounting Frame, 12 ¹ / ₂ "H x 10 ³ / ₈ "W x 1"D.
CWHS2	2" Semi-Recess Mounting Frame, 12 ¹ / ₂ "H x 10 ³ / ₈ "W x 2"D.

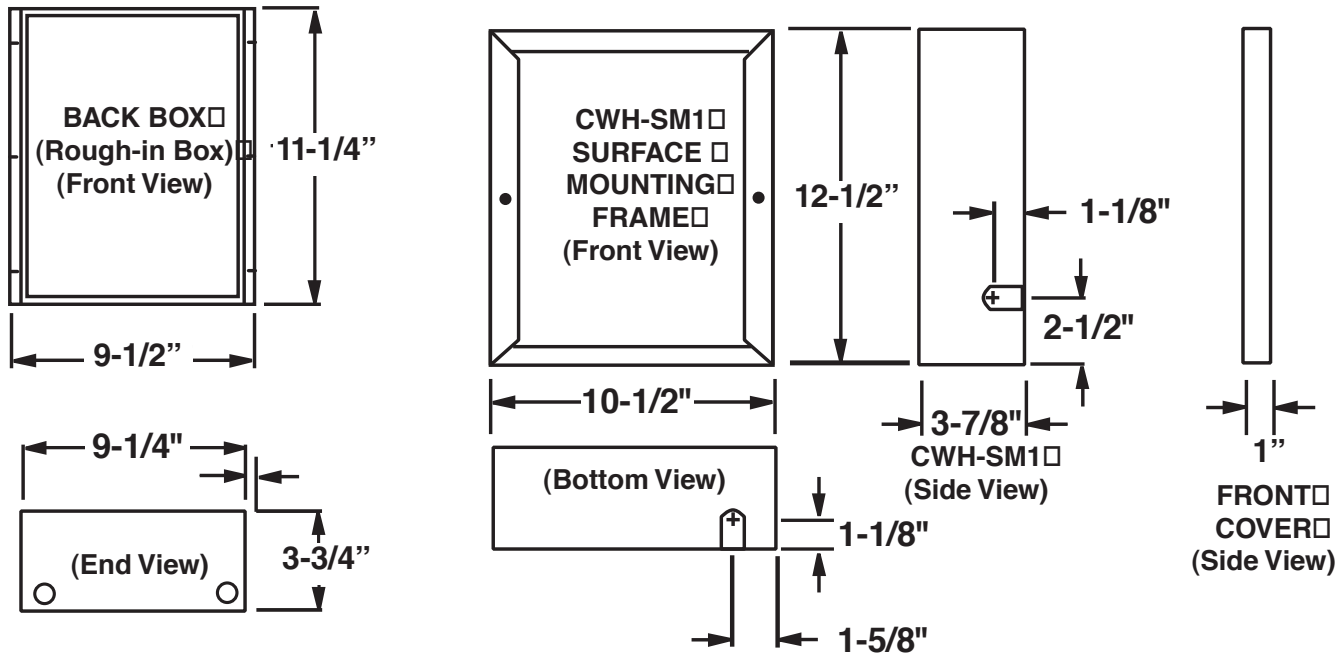

ARCHITECT'S AND ENGINEER'S SPECIFICATIONS

ARCHITECT'S AND ENGINEER'S SPECIFICATIONS*

The heating equipment shall include an electric automatic fan forced air heater suitable for small area heating, as manufactured by QMark, A Engineered Products Brand, Bennettsville, SC. The heater shall be designed for wall mounting, recess or surface. Heaters shall be UL listed.

BACKBOX: The backbox shall be designed for duty as a recessed rough-in box in either masonry or frame installations and is also used with the surface mounting frame in surface mounting installations. The backbox shall be heavy gauge galvanized steel and shall contain knockouts through which power leads are brought.

INNER FRAME ASSEMBLY: The heater assembly which fits into the backbox shall consist of a heavy gauge steel fan panel upon which is mounted all of the operational parts of the heater. The inner frame assembly shall be completely pre-wired.

HEATING ELEMENT: The heating element shall be of the non-glowing design consisting of an 80/20 nickel-chromium resistance wire enclosed in a steel sheath to which plate fins are copper brazed. It shall be warranted for 5 years. The element shall cover the entire air discharge area to ensure uniform heating of all discharge air.

MOTOR AND CONTROLS: The fan motor shall be impedance protected, permanently lubricated and with totally enclosed motor. Fan control shall be of the bi-metallic, snap-action type and shall activate fan after heating element reaches operating temperature, and continue to operate the fan after the thermostat is satisfied and until all heated air has been discharged. The thermostat shall be single pole type on all models. Thermal cutout shall be bi-metallic, snap-action type designed to shut off heat in the event of overheating. The fan shall be five-bladed aluminum. The fan motor shall be totally enclosed.

SURFACE MOUNTING FRAME: The surface mounting frame shall be of heavy gauge steel designed to mount around the backbox for a finished surface installation. Slot knock outs shall be provided for power supply conduit.

FRONT COVER: The louvered front cover shall be of heavy gauge steel with a powder paint finish. A plug button will be provided to replace the thermostat knob and render the unit tamper-resistant.

FINISH: All sheet metal parts, except the galvanized steel backbox, shall be phosphatized, then completely painted by a powder paint process.

**QMark reserves the right to change specifications without prior notice.*