

# ULTRA-BEAM™ model SU925QD-24

Ultrasonic Proximity Sensor with Switched (Relay) Output



The Banner 925 Series ULTRA-BEAM is an economical ultrasonic sensor with relay output and a sensing range of 20 inches to 20 feet (0,5 to 6 meters). ULTRA-BEAM "925" sensors are ideal for long-range proximity requirements which fall beyond the limits of photoelectric response, and are the solution for many applications which require reflective sensing of non-reflective materials. Popular applications include bin-level sensing/control and presence sensing of transparent materials.

Sensing range is easily adjusted using the top-mounted 15-turn clutched range control. When the range is set, objects passing through the sensor's area of response will be reliably sensed from the set range down to 16 inches from the face of the ULTRA-BEAM. The minimum range setting is 20 inches (0,5m). Objects which pass beyond the set range will be ignored. The ULTRA-BEAM has an easily-visible top mounted red LED indicator which lights whenever an object is detected.



For reliable detection, objects to be sensed must present at least one square foot (0,1 square meter) of surface area for each 10 feet of sensor-to-object distance.

The response curve (above) illustrates the sensing pattern which results for a 2 square foot target approaching from either side. The pattern is drawn for the maximum range setting of the ULTRA-BEAM. Symmetry of this pattern may be assumed in all sensing planes.

The ULTRA-BEAM is ruggedly constructed with epoxy-encapsulated circuitry and housed in a tough, corrosion-proof VALOX® enclosure. The ultrasonic transducer is protected by a stamped metal screen. The transducer will not be damaged by temporary contact with moisture, but must be kept free of heavy contamination for efficient operation. The output is an SPDT form "C" relay for easy interfacing to most loads (see specifications). An integral 5-pin minifast™ connector is standard. A mating industrial duty 12 foot cable, model MBCC-512, is sold separately.

The ULTRA-BEAM is ruggedly constructed with epoxy-encapsulated circuitry and housed in a tough, corrosion-proof VALOX® enclosure. The ultrasonic transducer is protected by a stamped metal screen. The transducer will not be damaged by temporary contact with moisture, but must be kept free of heavy contamination for efficient operation. The output is an SPDT form "C" relay for easy interfacing to most loads (see specifications). An integral 5-pin minifast™ connector is standard. A mating industrial duty 12 foot cable, model MBCC-512, is sold separately.

## SU925QD-24 (18 to 30V dc) with electromechanical relay output

### Response Pattern

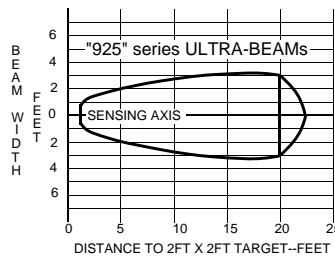

#### NOTES:

- 1) Response pattern is drawn for the maximum range setting of the ULTRA-BEAM.
- 2) Response pattern is drawn for a 2 square foot solid surface.
- 3) Symmetry of the pattern may be assumed in all sensing planes.
- 4) Rounded portion of curve past the 20 foot point indicates area where sensing is unreliable. Effective range is from 20 inches to 20 feet (0,5 to 6 meters).

### Specifications

**SUPPLY VOLTAGE:** model SU925QD-24, 18 to 30V dc, 4VA

**SENSING RANGE:** 20 inches to 20 feet (0,5 to 6 meters). Minimum required target area is 1 square foot (0.1 square meter) for each 10 feet (3 meters) of sensing range.

**SENSING HYSTERESIS:** 5% of range setting.

**RANGE ADJUSTMENT:** 15-turn clutched potentiometer with slotted brass element, located under o-ring gasketed access screw on top of sensor. Use small, flat-blade screwdriver to adjust.

**INDICATOR LED:** red LED indicator on top of sensor lights when object is sensed (when output relay is energized).

**RESPONSE TIME:** 100 milliseconds ON and OFF.

**OUTPUT:** one form "C" SPDT relay, silver-nickel alloy contacts.

*Capacity:* 150 watts or 600VA maximum power (resistive load).

*Maximum voltage:* 250V ac or 30V dc (resistive load).

*Maximum current:* 5 amps (resistive load).

*Minimum load:* 5V dc @ 100 milliamps.

*Mechanical life:* 10,000,000 operations.

**NOTE:** install suitable value metal oxide varistor (MOV) across contact(s) used to switch an inductive load.

**OUTPUT CONNECTOR:** integral 5-pin minifast™ threaded quick-disconnect. 12-foot mating cable, model MBCC-512, is sold separately (see information on following page).

**CONSTRUCTION:** Epoxy-encapsulated circuitry. Rugged, glass-filled VALOX® housing. NEMA 1, 3, and 12.

**OPERATING TEMPERATURE:** 0 to 50°C (32 to 122°F).



**WARNING** This ultrasonic sensing device does NOT include the self-checking redundant circuitry necessary to allow its use in personnel safety applications. A sensor failure or malfunction can result in either an energized or a de-energized sensor output condition.

Never use this product as a sensing device for personnel protection. Its use as a safety device may create an unsafe condition which could lead to serious injury or death.

Only MACHINE-GUARD and PERIMETER-GUARD Systems, and other systems so designated, are designed to meet OSHA and ANSI machine safety standards for point-of-operation guarding devices. No other Banner sensors or controls are designed to meet these standards, and they must NOT be used as sensing devices for personnel protection.

# ULTRA-BEAM SU925QD-24 Sensor

## Functional Schematic and Hookup Information

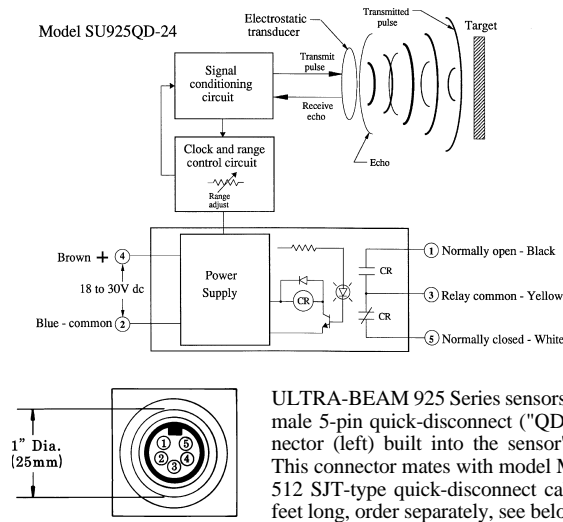

## Dimensions, SU925QD-24 Sensors

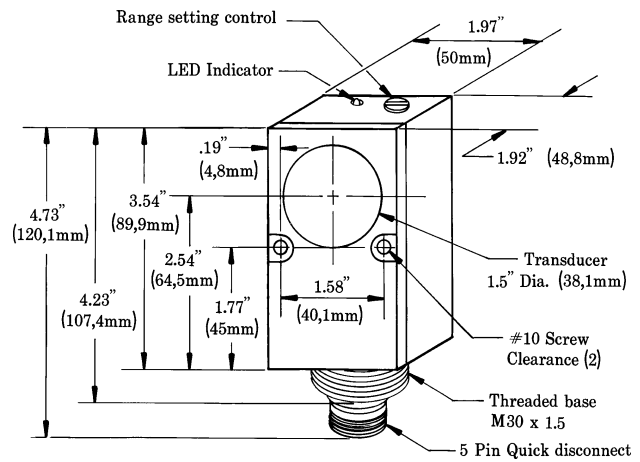

## Setup Procedure, SU925QD-24 ULTRA-BEAM Sensors

Proper operation of an ULTRA-BEAM 925 Series sensor requires that it be mounted securely, on a firm surface, at least 24 inches away from side walls. At least 48 inches is required between adjacent ULTRA-BEAMs with parallel sensing beams. Greater separation is required if the sensing beams cross. Less than 48 inches of separation is allowable if the adjacent sensing beams point away from each other.

With the ULTRA-BEAM mounted in place, set the object to be detected at the desired distance, with the surface to be detected directly in front of the sensor and perpendicular to the beam.

Turn the RANGE potentiometer to the fully counterclockwise position, then turn the control clockwise until the sensor's red LED indicator comes on. Verify this range setting by moving the object away from the sensor (LED should go out), then back towards the sensor (LED should come on again at about the same distance as before). It is best to set the range with the object at the maximum distance at which you expect to detect that object.

Minimum target size required for proper operation of the ULTRA-BEAM 925 Series sensor is about 1 square foot for each 10 feet of sensor-to-object distance.

## Accessories for 925 Series ULTRA-BEAM Sensors

**minifast™ model MBCC-512 Quick Disconnect ("QD") CABLE: 5-conductor SJT-type cable in 12 foot lengths**

Cable Connector Side View

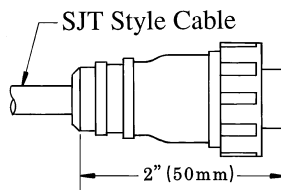

Cable Connector End View

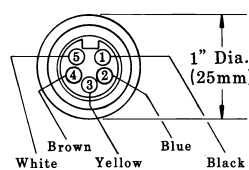

To Fit Sensor Base

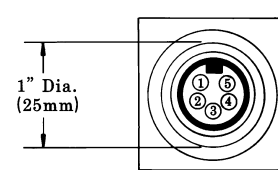

Model SMB900 bracket



**Accessory mounting bracket model SMB900** has curved mounting slots for versatility in mounting and orientation. The sensor mounts to the bracket by its threaded base, using a jam nut and lockwasher (both included). The bracket material is 11-gauge zinc-plated steel. The curved mounting slots have clearance for 1/4" screws.

An internal tooth lockwasher and hex mounting nut are supplied with the sensor.

