

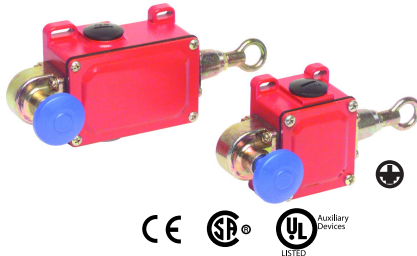

Rope Pull Switches



Datasheet

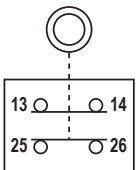
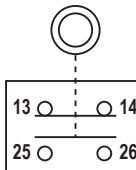
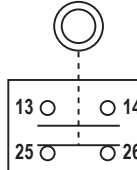
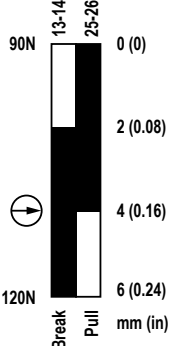
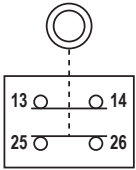
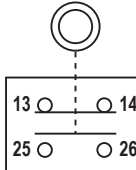
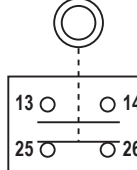
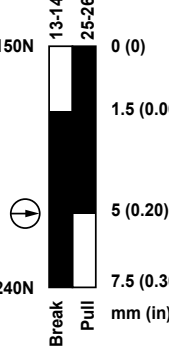

-  Positive-opening safety contacts (IEC 60947-5-1), not dependent upon springs
- Both safety contacts latch open when rope is pulled or in case of a broken wire; requires manual reset
- Heavy-duty die cast metal housing, rated IP65, suitable for demanding industrial environments
- Rope spans up to 6 m, 12 m or 20 m (20 ft, 40 ft, or 66 ft), depending on model
- Both safety contacts are closed with normal rope tension; one contact opens when rope is pulled, the other contact opens if rope breaks (or if tension is reduced from normal amount)
- Some models include extra contacts for monitoring or to provide dual-channel input to a safety device
- Indicator mark on switch shows when rope has proper tension for operation
- Long life, switch rated at 1 million mechanical operations, minimum
- Five available models; all with latching outputs
-  Protective Earth Terminal (IEC 60947-1)

Model	Max. Rope Length	Run Position	Cable Pulled	Cable Break	Switching Diagram
RP-QM72D-6L	6 m (20 ft)				
RP-QM72D-12L	12 m (40 ft)				

Model	Max. Rope Length	Run Position	Cable Pulled	Cable Break	Switching Diagram
RP-QMT72D-20L	20 m (65 ft)				



NOTE: This symbol  for a positive-opening safety contact (IEC 60947-5-1) is used in the switching diagram to identify the point in actuator travel where the normally-closed safety contact is fully open.

Model	Max. Rope Length	Run Position	Cable Pulled	Cable Break	Switching Diagram
RP-QMT72F-12L	12 m (40 ft)				
RP-QMT72E-12L	12 m (40 ft)				

Contacts:  Open  Closed  Transition



NOTE: This symbol  for a positive-opening safety contact (IEC 60947-5-1) is used in the switching diagram to identify the point in actuator travel where the normally-closed safety contact is fully open.

Important... Read This First

Regarding the Use of Rope Pull Switches. In the United States, the functions that Banner rope pull switches are intended to perform are regulated by the Occupational Safety and Health Administration (OSHA). Whether or not any particular rope pull switch installation meets all applicable OSHA requirements depends upon factors that are beyond the control of Banner Engineering Corp. These factors include the details of how the switches are applied, installed, wired, operated, and maintained.

Banner Engineering Corp. has attempted to provide complete application, installation, operation, and maintenance instructions in this document. Direct any questions regarding the use or installation of rope pull switches to the factory applications department.

Banner Engineering Corp. recommends that rope pull switches be applied according to the guidelines set forth in the standards listed below. In addition, the user is responsible for ensuring all local, state, and national laws, rules, codes, and regulations relating to the use of Banner rope pull switches in each application are satisfied. Extreme care is urged that all legal requirements are met and that all installation and maintenance instructions are followed.

Applicable U.S. Standards

OSHA Code of Federal Regulations: Title 29, Parts 1900 to 1910

Available from: Superintendent of Documents, Government Printing Office, P.O. Box 371954, Pittsburgh, PA 15250-7954, Tel: 202-512-1800

ANSI B11 Standards for Machine Tools Safety

Contact: Safety Director, AMT – The Association for Manufacturing Technology, 7901 Westpark Drive, McLean, VA 22102, Tel.: 703-893-2900

Applicable European and International Standards

ISO/TR 12100-1 (EN 292-1 & -2) Safety of Machinery – Basic Concepts, General Principles for Design

ISO 13852 (EN 294) Safety of Machinery—Safety Distances to Prevent Danger Zones Being Reached by the Upper Limbs

ISO 13853 (EN 811) Safety of Machinery—Safety Distances to Prevent Danger Zones Being Reached by the Lower Limbs

ISO 13849-1 (EN 954-1) Safety-Related Parts of Control Systems

ISO 13855 (EN 999) The Positioning of Protective Equipment in Respect to Approach Speeds of Parts of the Human Body

ISO 14119 (EN 1088) Interlocking Devices Associated with Guards – Principles for Design and Selection

IEC 60204-1 Electrical Equipment of Machines Part 1: General Requirements

IEC 60947-5-1 Low Voltage Switchgear – Electromechanical Control Circuit Devices

Contact: Global Engineering Documents, 15 Inverness Way East, Englewood, CO 80112-5704, Tel.: 800-854- 7179

Overview

Models RP-QM..72-..L are rope pull switches in heavy-duty metal housings. When used with steel wire rope, they can provide stop actuation along conveyors and similar machinery. Red PVC-covered 3 mm diameter wire rope is recommended (see Accessories).

Some models have redundant terminal pairs (see model listing). In such models, terminals 33/34 will follow the action of terminals 13/14 and terminals 45/46 will follow the action of terminals 25/26. Either or both contacts 33/34 and/or 45/46 may be used as monitoring contacts. Contact pairs 33/34 also may be jumpered to pairs 45/46 (in the same way that 13/14 is jumpered to 25/26) to provide dual-channel input to a safety device. When the rope is properly tensioned (using a turnbuckle), both contacts of the switch are closed. A groove on the actuator aligns with the end of the housing flange when tension is set for operation. When the rope is pulled, the positive-break contact between terminals 25 and 26 (and terminals 45 and 46, for model RP-QMT72E-12L) latches open. If the rope breaks or goes slack, the contact between terminals 13 and 14 (and terminals 33 and 34, for models RP-QMT72E-12L and RP-QMT72F-12L) opens. These contacts typically should be wired together, in series.

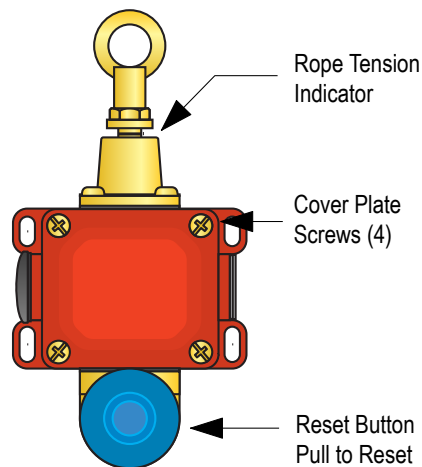

Figure 1. Features

These rope pull switches are not safeguarding devices, in that they do not protect personnel from injury. They provide the same function as other types of stop switches.

All five models feature “latching” operation. When the rope is pulled, the switch contacts 25/26 (and 45/46, depending on model) open and remain open until the built-in reset button is manually pulled to reset.



WARNING: Not a Safeguarding Device

An Emergency Stop Device is not considered a safeguarding device because it requires an overt action by an individual to stop machine motion or hazards.

A safeguarding device limits or eliminates an individual's exposure to a hazard *without action by the individual or others*. Because an individual must actuate the device for it to function, these devices do not fit the definition of a safeguarding device and cannot be substituted for required safeguarding. Refer to the relevant standards to determine those requirements.

Mechanical Installation

Installation Guidelines

- The rope should be easily accessible and visible along its entire length. Markers or flags may be fixed on the rope to increase its visibility
- Mounting points, including support points, must be rigid and allow sufficient space around the rope to allow easy access
- The rope should be free of friction at all supports. Pulleys are recommended
- Use only pulleys (not eye bolts) when routing the rope around a corner or whenever direction changes, even slightly
- Never run rope through conduit or other tubing
- Never attach weights to the rope
- Temperature affects rope tension. The rope expands (lengthens) when temperature increases, and contracts (shrinks) when temperature decreases. Significant temperature variations require frequent checks of the tension adjustment
- Do not exceed the maximum specified total rope length. Banner offers models for other spans; contact Banner Engineering or visit www.bannerengineering.com for model selection

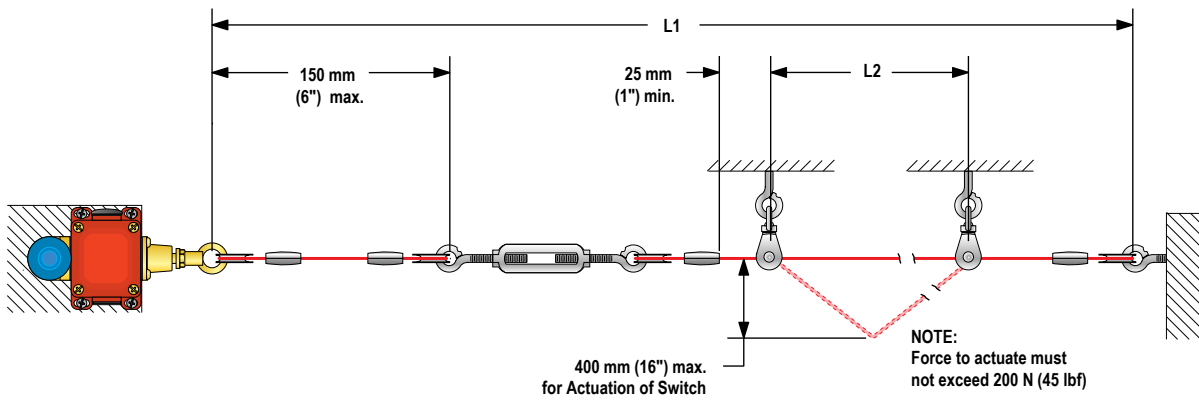

Figure 2. Assembly of Rope and Hardware

Model	Max. Total Length L1	Max. Distance Between Pulleys L2
RP-QM72D-6L	6 m (20 ft)	3 m (10 ft)
RP-QM72D-12L	12 m (40 ft)	4 m (13 ft)
RP-QMT72D-20L	20 m (66 ft)	5 m (17 ft)
RP-QMT72E-12L	12 m (40 ft)	4 m (13 ft)
RP-QMT72F-12L	12 m (40 ft)	4 m (13 ft)

Installation Procedure

1. Mount the switch securely on a solid, stationary surface.
2. Fasten an eye bolt at the opposite end of the rope span, up to 6 m (20 ft), or 12 m (40 ft) or 20 m (66 ft) from the switch, depending on model. The anchor for the eye bolt also must be solid and stationary, to withstand the constant tension of the rope.
3. Assemble the rope, as shown. Keep the rope's PVC cover intact along its complete length.
4. Use pulleys (recommended) or eye bolts at each support point. A pulley must be used when routing the rope around a corner, regardless of the angle.
5. Apply tension to the rope using the turnbuckle until the indicator mark on the switch aligns with the leading edge of the housing flange. This indicates sufficient rope tension. (Contacts 25/26, and 45/46, if applicable, will close.)
6. Pull hard on the rope and reset the latch several times. If contact 25/26 (45/46) remains open following the reset, further tighten the turnbuckle, until contact 25/26 (45/46) closes.
7. Repeat step 6 until contact 25/26 (45/46) remains closed for the Run condition.

All hardware is supplied by the user. The switch mounting holes are on a mounting pattern of 72 x 40 or 72 x 76 millimeters, and accept M5 (#10) hardware. Wire rope and associated hardware may be ordered separately; see *Accessories*.

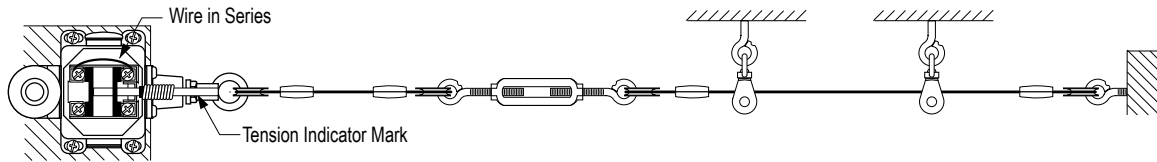

Figure 3. Run Position: Proper Rope Tension

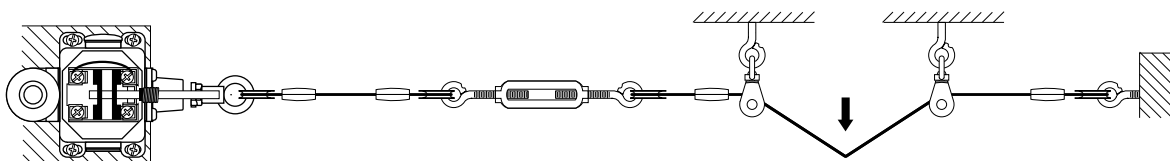

Figure 4. Rope Pulled: Contact 25/26 (45/46) Opens

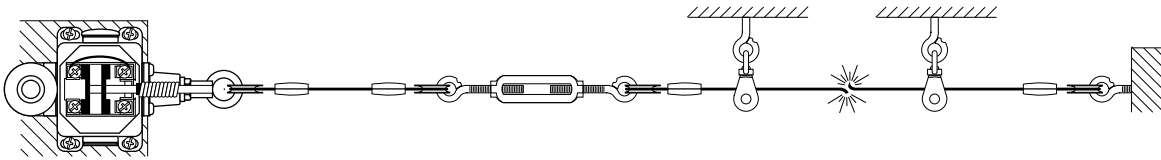

Figure 5. Rope Break or Slack: Contact 13/14 (33/34) Opens

Electrical Installation

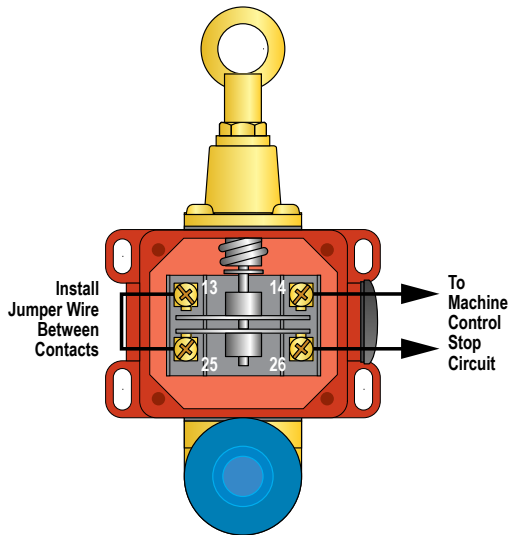

Figure 6. Wire the two switch contacts in series

Access to the Wiring Chamber. The wiring chamber is accessed via a cover plate (remove four screws). A conduit adapter is supplied to convert the 20 millimeter threaded entrance to 1/2-inch NPT. An accessory cable gland that fits the M20 thread is also available (see *Accessories*).

Wiring. Install a jumper wire to place switch contacts 13/14 and 25/26 in series, as shown.

For model RP-QMT72F-12L, install a jumper wire to place contacts 33/34 and 45/46 in series, to provide a dual-channel output to a safety device. If dual-channel output is not required, either or both contacts may instead be used as monitoring outputs (in which case no jumper is required).

Maintenance/Checkout

At switch installation or replacement and at machine set up, a Designated Person¹ must test each switch for proper machine shutdown response and check the switch(es) and installation for proper operation, physical damage, mounting (looseness), and excessive environmental contamination. This must also take place on a periodic schedule determined by the user, based on the severity of the operating environment and the frequency of switch actuations. Adjust, repair, or replace components as needed. If inspection reveals contamination on the switch, thoroughly clean the switch and eliminate the cause of the contamination. Replace the switch and/or appropriate components when any parts or assemblies are damaged, broken, deformed, or badly worn; or if the electrical/mechanical specifications (for the environment and operating conditions) have been exceeded. Always test the control system for proper functioning under machine control conditions after performing maintenance, replacing the switch, or replacing any component of the switch.

Additional items that should be included in the checkout and/or regularly scheduled maintenance of a rope pull system:

- Check for proper rope tension and adjust as needed
- Verify free operation (no binding) of the rope and proper tripping when the rope is pulled
- Periodically lubricate the pulleys and other moving parts associated with the rope
- Repair any loose or damaged hardware, worn/frayed rope (cable), missing red rope sheathing or flags/markers (if used)
- Remove or clean off any contamination and eliminate its cause

Repairs

Contact Banner Engineering for troubleshooting of this device. Do not attempt any repairs to this Banner device; it contains no field-replaceable components. If the device or a device component is determined to be defective by a Banner Applications Engineer, they will advise you of Banner's RMA (Return Merchandise Authorization) procedure.

¹ A Designated Person is identified in writing by the employer as being appropriately trained to perform a specified checkout procedure.



Important: If instructed to return the device, pack it with care. Damage that occurs in return shipping is not covered by warranty.

Specifications

Contact Rating

- 10 A at 24 V ac
- 10 A at 110 V ac
- 6 A at 230 V ac
- 6 A at 24V dc
- 2.5 kV max. transient tolerance
- NEMA A300 P300

European Rating

- Utilization categories: AC15 and DC13
- Ui = 500 V ac; Ith = 10 A

40-60 Hz		
Ue (V)	Ie/AC-15 (A)	Ie/DC-13 (A)
24	10	6
110	10	1
230	6	0.4

Contact Material

Silver-nickel allow

Maximum Switching Speed

50 operations per minute

Recommended Rope Size

3 mm diameter steel rope

Maximum Rope Pull Length

- RP-QM72D-6L: 6 m (20 ft)
- RP-QM72D-12L: 12 m (40 ft)
- RP-QMT72D-20L: 20 m (66 ft)
- RP-QMT72E-12L: 12 m (40 ft)
- RP-QMT72F-12L: 12 m (40 ft)

Short Circuit Protection

10 amp Slow Blow, 15 amp Fast Blow. Recommended external fusing or overload protection.

Mechanical Life

1 million operations

Wire Connections

- Screw terminals with pressure plates accept the following wire sizes –
- Stranded and solid: 20 AWG (0.5 mm²) to 16 AWG (1.5 mm²) for one wire
- Stranded: 20 AWG (0.5 mm²) to 18 AWG (1.0 mm²) for two wires

Cable Entry

M20 x 1.5 threaded entrance. Adapter supplied to convert M20 x 1.5 to ½"-14 NPST threaded entrance

Construction

Aluminum alloy die-cast

Environmental Rating

IEC IP65

Operating Conditions

Temperature: -30 to 80 °C (-22 to 176 °F)

Weight

- RP-QM72D-6L: 0.49 Kg (1.08 lbs)
- RP-QM72D-12L: 0.52 Kg (1.15 lbs)
- RP-QMT72D-20L: 0.64 Kg (1.41 lbs)
- RP-QMT72E-12L: 0.64 Kg (1.41 lbs)
- RP-QMT72F-12L: 0.64 Kg (1.41 lbs)

Certifications



Dimensions

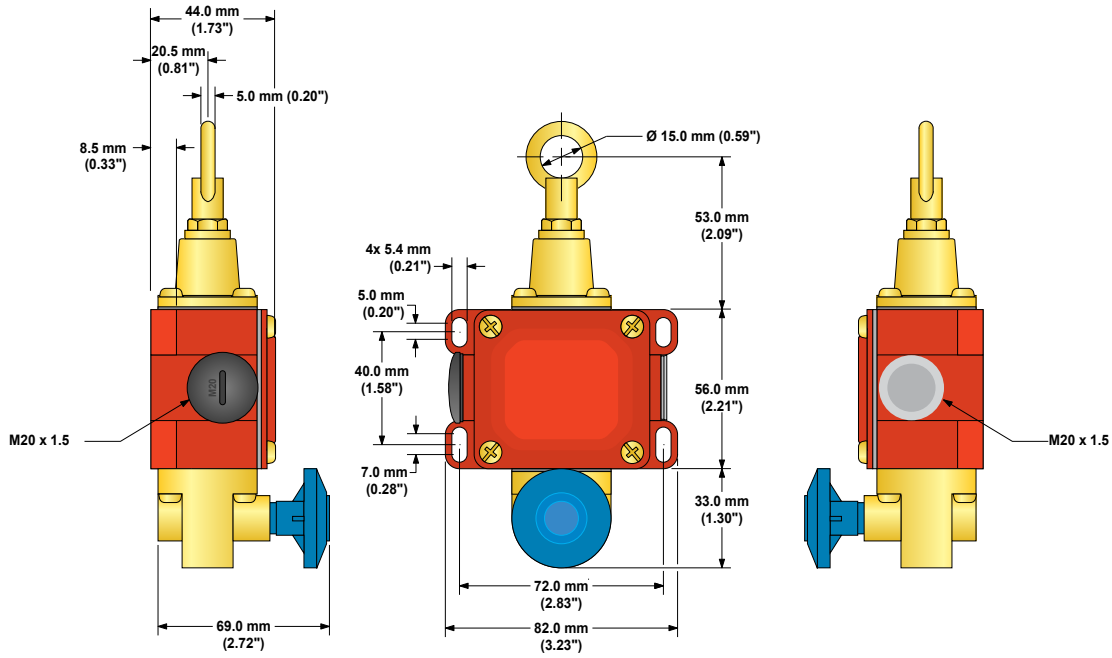

Figure 7. RP-QM72D-6L and RP-QM72D-12L

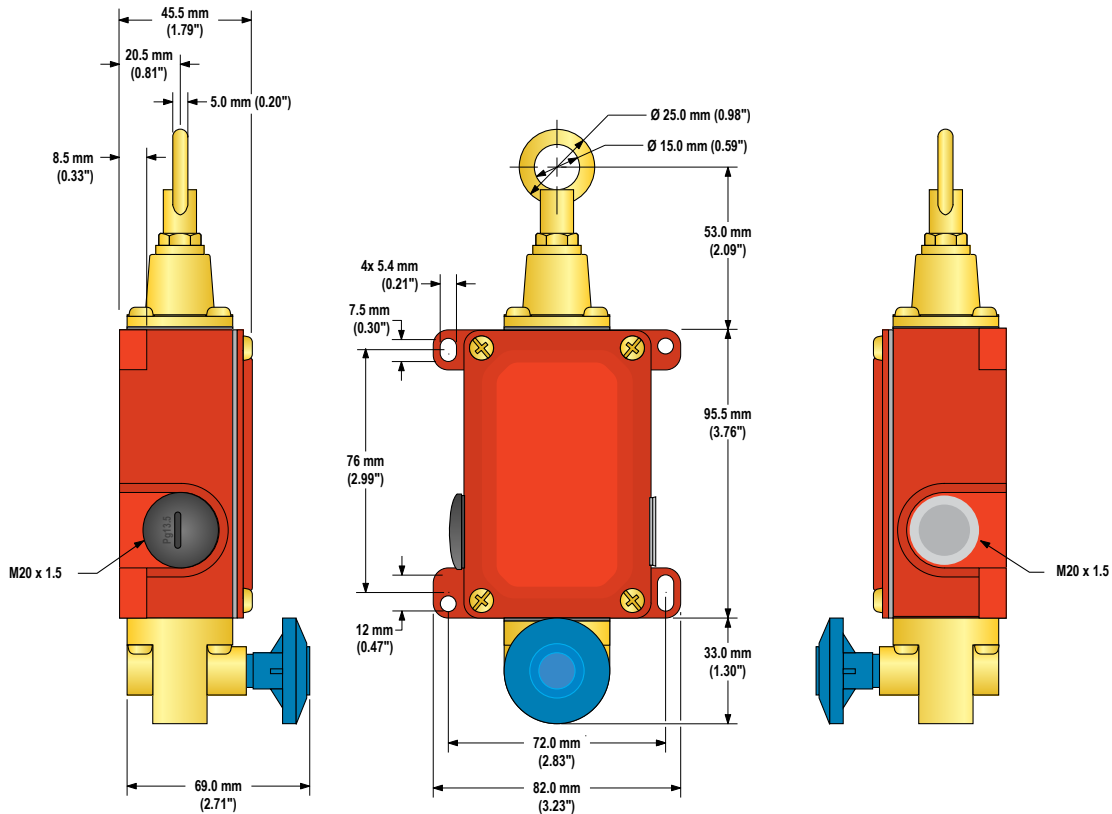

Figure 8. RP-QMT72D-20L, RP-QMT72E-12L, and RP-QMT72F-12L

Accessories

Cable Glands

Model	Size	For Cable Diameter	Dimensions	Used With
SI-QM-CGM20	M20 x 1.5 Metal	5.0 to 12.0 mm (0.20 to 0.47 inches)		SI-LM40 Safety Interlock Switches SI-QM100 Safety Interlock Switches RP-RM83 Rope Pull Switches RP-LM40 Rope Pull Switches RP-QM72/QMT72 Rope Pull Switches RP-QM90 Rope Pull Switches

Conduit Adapters

Model	Size	Thread Conversion	Dimensions	Used With
SI-QM-M20	½ in-14 NPT Metal	M20 x 1.5 to ½ in-14 NPT		SI-LM40 Safety Interlock Switches SI-QM100 Safety Interlock Switches RP-RM83 Rope Pull Switches RP-LM40 Rope Pull Switches RP-QM72/QMT72 Rope Pull Switches RP-QM90 Rope Pull Switches

One conduit adapter is supplied with each switch.

Components for the Wire Rope Assembly

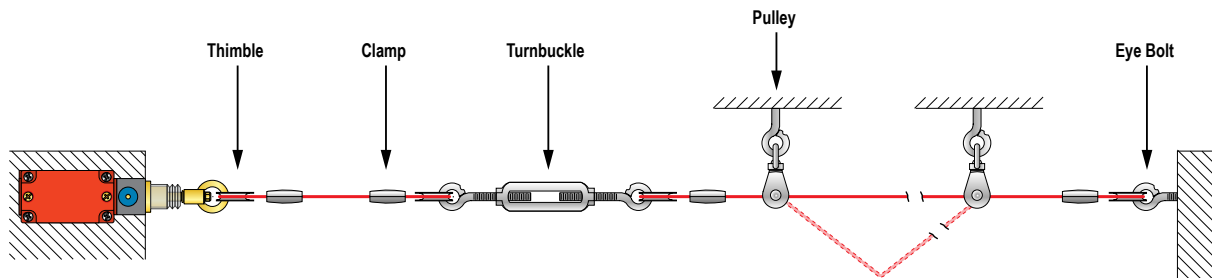



Model	Length	Description	Wire Rope
RPA-C2-10	10 m (33 ft)	3 mm steel wire rope with 0.5 mm red PVC jacket (unterminated)	
RPA-C2-20	20 m (66 ft)		
RPA-C2-50	50 m (264 ft)		
RPA-C2-80	80 m (264 ft)		

Model	Quantity	Description	Thimble
RPA-T2-4	4	Thimble for 3 mm wire rope	

Model	Quantity	Description	Clamp
RPA-CC2-4	4	Clamp for 3 mm wire rope	

Model	Quantity	Description	Turnbuckle
RPA-TA1-1	1	#4 Turnbuckle	

Model	Quantity	Description	Eye Bolt
RPA-EB1-1	1	¼"-20 Eye bolt (3" bolt shaft)	

Model	Quantity	Description	Pulley
RPA-P1-1	1	Hanging pulley for in-line use	

Banner Engineering Corp Limited Warranty

Banner Engineering Corp. warrants its products to be free from defects in material and workmanship for one year following the date of shipment. Banner Engineering Corp. will repair or replace, free of charge, any product of its manufacture which, at the time it is returned to the factory, is found to have been defective during the warranty period. This warranty does not cover damage or liability for misuse, abuse, or the improper application or installation of the Banner product.

THIS LIMITED WARRANTY IS EXCLUSIVE AND IN LIEU OF ALL OTHER WARRANTIES WHETHER EXPRESS OR IMPLIED (INCLUDING, WITHOUT LIMITATION, ANY WARRANTY OF MERCHANTABILITY OR FITNESS FOR A PARTICULAR PURPOSE), AND WHETHER ARISING UNDER COURSE OF PERFORMANCE, COURSE OF DEALING OR TRADE USAGE.

This Warranty is exclusive and limited to repair or, at the discretion of Banner Engineering Corp., replacement. IN NO EVENT SHALL BANNER ENGINEERING CORP. BE LIABLE TO BUYER OR ANY OTHER PERSON OR ENTITY FOR ANY EXTRA COSTS, EXPENSES, LOSSES, LOSS OF PROFITS, OR ANY INCIDENTAL, CONSEQUENTIAL OR SPECIAL DAMAGES RESULTING FROM ANY PRODUCT DEFECT OR FROM THE USE OR INABILITY TO USE THE PRODUCT, WHETHER ARISING IN CONTRACT OR WARRANTY, STATUTE, TORT, STRICT LIABILITY, NEGLIGENCE, OR OTHERWISE.

Banner Engineering Corp. reserves the right to change, modify or improve the design of the product without assuming any obligations or liabilities relating to any product previously manufactured by Banner Engineering Corp.